

Taig Standard Front Tool Post

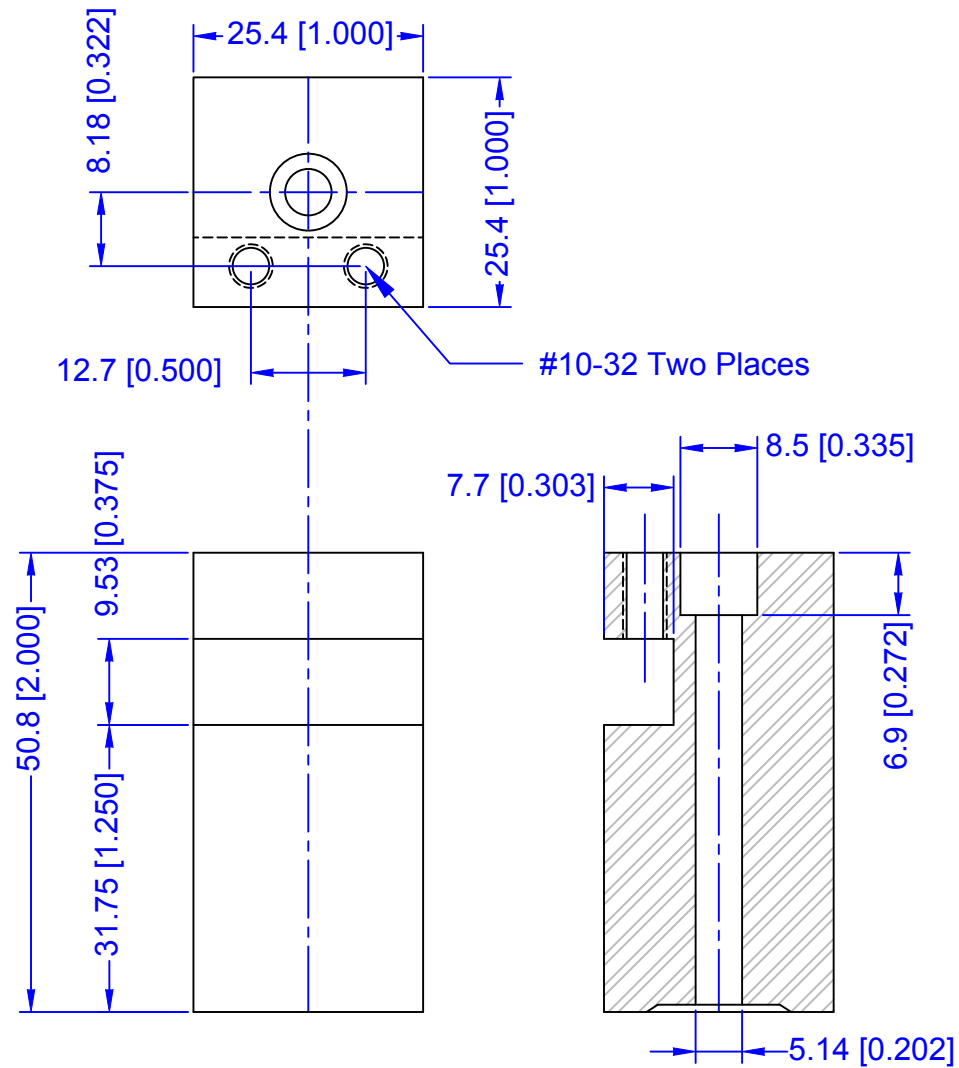

Taig Standard Back Tool Post

NOTE:

I have at least six of the front Tool Posts and two of the rear Tool Posts. The tool height on all of them is consistently 10 to 20 thousands of an inch shorter than shown above.

This document/file is placed in the **PUBLIC DOMAIN**. The author assumes no liability for the accuracy, fitness or application of the information or design herein. Lewis Balentine, Houston, Texas, 9 February 2020

Unless otherwise noted all dimesions are in millimeters [inches]